

# IPPhone to Phone System

## About Company

In such a highly competitive business scenario, where distance cannot be an excuse for an unsuccessful business relationship, AdoreInfotech brings a revolutionary communicating medium for all those established and aspiring business tycoons, who want to have a cutting edge in the market. With AdoreInfotech's Softphone one can enjoy all the benefits of immediate one-on-one communication in order to build up potential customers resulting in increased customer loyalty, more and positive customer feedback.

We, at AdoreInfotech, offer our clients following suite of efficient and modern telecom solutions with ensured smoothness in functionality:

- All In One System
- Soft Switch
- VoIP Billing
- Calling Card
- Callback
- IP PBX
- IAX Solution
- Call Shop
- Pc to Phone System
- Softphone
- Web2Phone

AdoreInfotech believes in long term relationship and that's why provides Free Demonstration and Training to its clients for all its products. This not only helps the clients to understand more about our products but also strengthen the business relationship. Apart from providing genuine VoIP Software required in setting up the VoIP Service, we also impart consultancy services to our partners, which make you acquainted with step by step set up of your VOIP network.

With competent team and up-to-date telecom solutions, AdoreInfotech has always remained a step forward in creating client friendly products and innovative solutions and always starved to keep abreast with the changing market scenario.

## Adore IPPhone2Phone

Adore IPPhone2Phone System allows Internet Telephony Service Provider (ITSP) providing uninterrupted IPPone2Phone and IPPhone2IPPhone services to our worldwide clients.

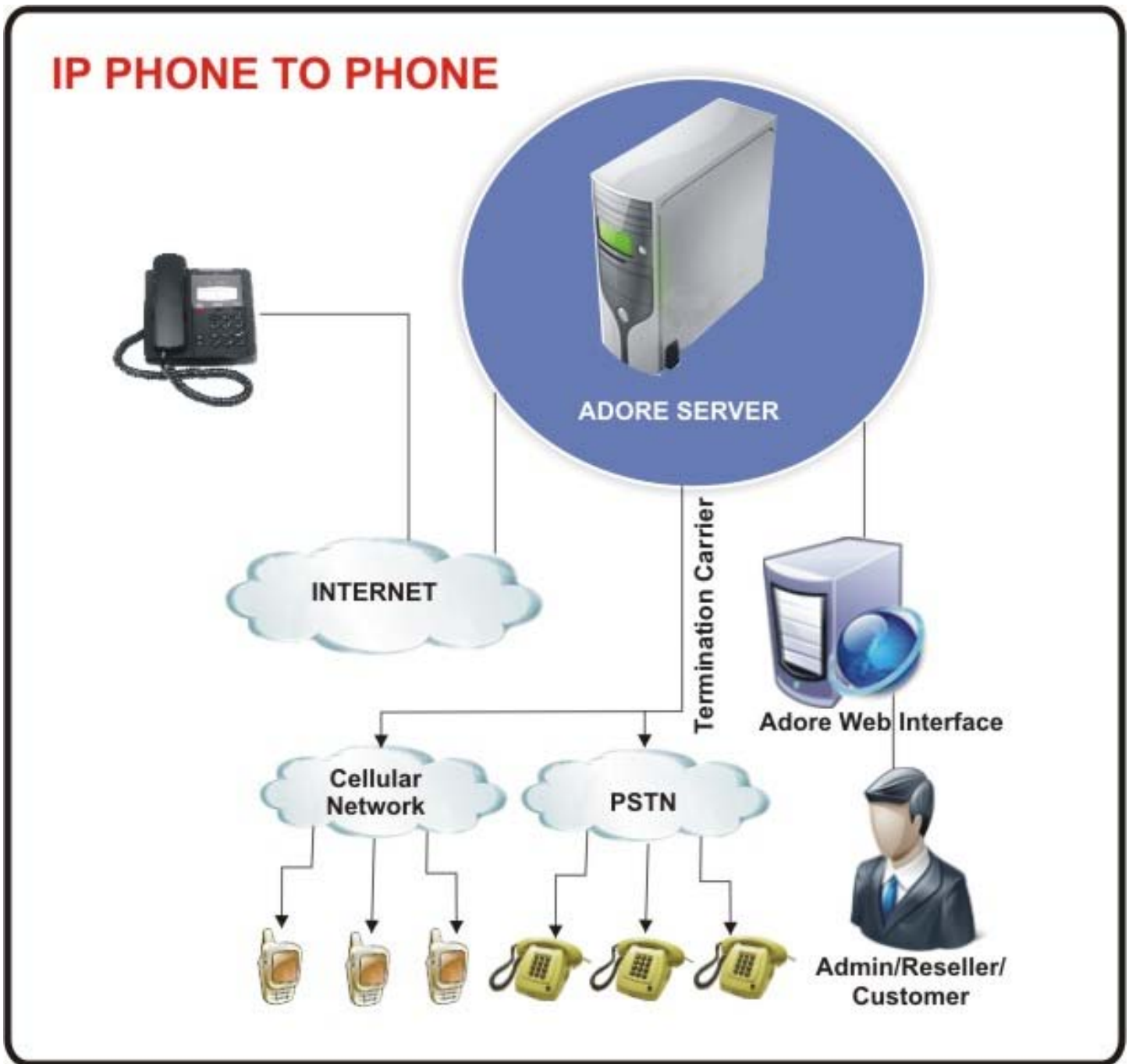

AdoreInfotech endeavors to localize universal communication and interaction at very minimal rates with no hassles. By making PC to Phone or Phone to PC technologies familiar and popular to its unending clientele, Adore Infotech is here to offer its clients one more exciting option of interaction, i.e. IP Phone to Phone and IP Device to Phone.

To meet the requirement of our users, i.e. lowest rates with the highest quality of service, we continuously add more and more options in our suite of services and IP Phone to traditional Phone fulfills the desired condition. With ease of use and chaos free setup, this technology helps you to create global interaction in no time with lesser hitches.

This facility allows the users to place domestic and international calls from IP Phone to traditional device. Unlike PC to PC or PC to Phone technologies, IP Phone to Phone lets the users to reach any regular telephone, without requiring any PC and shows more easy ways to communicate worldwide. This technology only requires hardware such as IP Phone.

### **IP Phone2Phone Component**

- Softswitch
- Billing System
- Two day Remote Training Program
- One month Remote support package

### **Softswitch & Billing System:**

- IVR
- Caller ID & Card Number and SIP/IAX2 Friend authentication
- Customize the IVR rapidly, chose to play Balance, Time to call, Intro prompt, etc...
- Recording of all calls
- Speed-dial
- Free VoIP calls between application users
- Support simultaneous or single access on same card
- Support call at Zero-Cost & Negative cost
- Auto creation card option for new CallerID
- Top-up account via IVR menu.
- Advanced Card and Customer management: Creation; Edit; Search engine; batch update; CallerID handling; Refill Cards.
- Define: post-pay/prepay; Language; Currency; Expiry; VAT; Recurring Service, User Data, etc...
- SIP / IAX Friends + ARA support
- Reporting statistics: CDR ; Maximum Concurrent calls ; Graphing ; Profit Margin analysis
- LCR(Least cost routing) & LCD (Least Cost Dialing) management
- Billing Increment: Progressively different rates through the call
- Scheduled Rates (days/hours of the weeks - PEAK & OFF-PEAK)
- Expiry of rates;

- Import Rate Cards
- Rate-card Simulator
- Trunk/VoIP-provider management
- Failover Trunks
- Batch update for rates
- Subscription services
- DID SALES
- Manage your DIDs and sell them to your customer for monthly usage.
- Customer can reserve DIDs for themselves and configure a Follow-me to redirect the calls over the PSTN by VoIP.
- Monthly & daily reporting
- Earnings calculation and markup/margin on report
- Monthly traffic reports (pie chart)
- Daily load
- Compare call-load with previous days
- Criteria definition for reporting
- Export report to PDF & CSV
- Generate invoices to PDF format
- Email invoices to customers Automatically
- Calling Card PIN based

### **Online Shop**

- Check the Customers balance; see Refills made, payment received, amount to pay.
- browse online payments made by PayPal, Authorize.net and Money booker
- Voucher support: creation; browsing; batch creation.
- Multi-Currencies support: automatic update based currently base on Yahoo Financial.
- Calling Packages - X number free minutes to specified destinations

### **DID Management System**

- DID SALES
- Manage your DIDs and sell them to your customer for monthly usage.
- Customer can reserve DIDs for themselves and configure a Follow-me to redirect the calls over the PSTN by VoIP.
- Monthly & daily reporting

### **Additional Features**

- Multi-Language support (Customer Interface)- force specific language, give a menu for language choices
- Play balance with multi currency support
- Auto refill existing card with auto refill option
- Periodically remove credit from customer balance
- E-Product : allows interaction with third party ecommerce platforms in order to create cards such as OS-commerce
- Signup modules

- Email activation to verify customer email address.
- Customize mail templates
- ACL (Access control) support for admin users
- DB backup/restore tool
- Export data into XML or CSV
- API to display rate card on own website

## **Reseller/Agent Module**

- Account Information
- Buy Credit
- Change Password
- List Customers
- Refill the customer through interface
- Search cards
- Update the whole batch
- Card history (month wise and day wise)
- Create customer (SIP and IAX)
- Generate customers
- Create more than one pin under one customer
- Create sign up url
- View money situations
- View own refill
- View own payments
- View customer refill
- View customer payment
- Make customer payment
- Payment log
- Browse rate
- CDR - customer wise, date wise, called number wise, source wise, dnid wise, call type wise, and other options wise
- Monthly traffic - customer wise, called number wise
- View customer tickets
- Create and view own tickets

## **Customer Module**

- Online signup, selection of tariff, language and currency with email verification.
- Account info, including update details
- Call history - CDR
- Voucher usage and voucher entry.
- Invoice Viewing
- DID selling support - features to sell to pre-configure DID. Customers can redirect DID to his phone-number and even deploy a Follow-Me

- Speed dial configuration
- Rate card browsing & rate card simulator
- Web based callback
- Caller id : list / add so that customer can authenticate to the service without needing to enter account and PIN
- Multi-Language support for the customer interface (Spanish, English, French, Chinese, Italian, Romanian, Turkish, Urdu)
- Forget password option

### Gateway Supported:

- Cisco
- Quintum

### How Adore IPPhone2Phone Works?

#### Registration Process

This is user agent (IP Phone) registration process diagram.

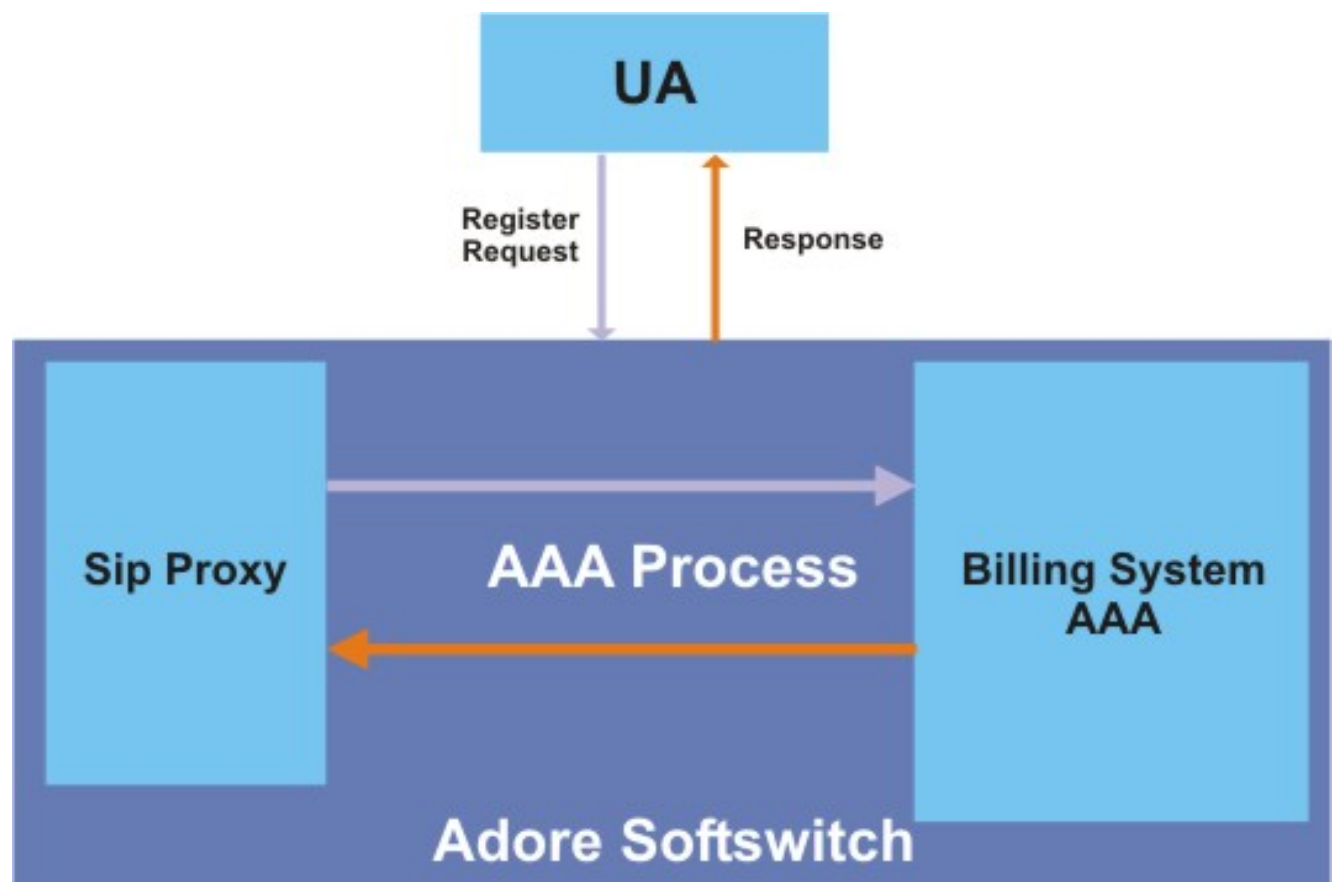

## IP Phone Registered

IP phone registered with one account



```
-- Registered SIP '2971' at 22.160.65.25 port 61497 expires 3600  
-- Unregistered SIP '2971'  
-- Registered SIP '2971' at 22.160.65.25 port 61497 expires 3600
```

## Registration Process Flow Diagram



## Call Flow Diagram

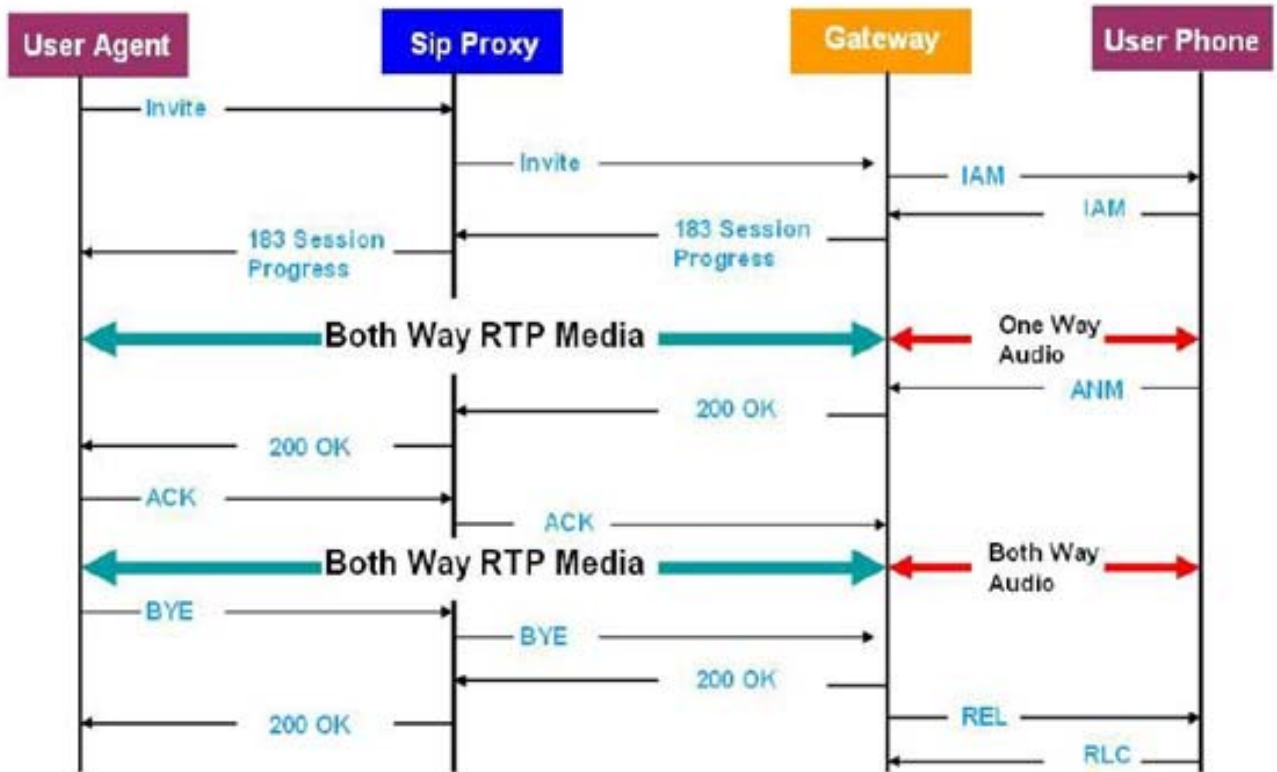

## Calls Detail Reports



[My Account](#)
[History](#)
[Invoices](#)
[DID](#)
[Speed Dial](#)
[Ratecard](#)
[Callback](#)
[Voucher](#)
[Caller ID](#)
[Misc Services](#)
[Support](#)
[Logout](#)

[USER MANUAL](#)

DATE	
FROM :	01 FEBRUARY-2009
TO :	01 FEBRUARY-2009
DESTINATION	
Destination	
<input checked="" type="radio"/> Exact	<input type="radio"/> Begins with
<input type="radio"/> Contains	<input type="radio"/> End with
CALL TYPE	
Select Call Type	ALL CALLS
OPTIONS	
SHOW :	Answered Calls <input checked="" type="radio"/> All Calls <input type="radio"/>
RESULT :	Minutes <input checked="" type="radio"/> - Seconds <input type="radio"/>
CURRENCY :	U.S. Dollar (USD) (1.00000)
<a href="#">Search</a>	

Number of Calls : 2

### Logs -

Calldate	Source	PhoneNumber	Destination	Duration	TC	Calltype	Cost
02/06/2009 08:03	123456	919899589069		00:00	CONGESTION	STANDARD	0.000 usd
02/06/2009 08:02	123456	919911881985	India	01:00		CALLBACK	0.200 usd

1 / 1

## VOIP Billing Admin Module



Welcome: r

[Customer](#) | [Agent](#) | [Ratecard](#) | [Callback](#) | [DID And Package](#) | [Billing & Invoices](#) | [Report](#) | [Trunk](#) | [Admin](#) | [Misc](#) | [Support](#) | [Logout](#)

- ▶ Authentication, authorization, accounting and real time VOIP billing.
- ▶ Customer management system.
- ▶ Powerfull RATE-ENGINE.
- ▶ Recurring Service Over The Card.
- ▶ Auto creation card option for new callerID.

[Many More...](#)

A photograph of four business professionals (three men and one woman) in an office setting, smiling and looking at a laptop screen. The image is framed by a blue, wavy border.

**Adore Billing**  
Helping you to communicate faster.

## VOIP Billing Reseller Module



Welcome: 123456

[My Account](#) | [Customers](#) | [Signup](#) | [Billing](#) | [Ratecard](#) | [Call Report](#) | [Support](#) | [Logout](#)



- \* Authentication, authorization, accounting and real time VOIP billing.
- \* Customer management system.
- \* Powerfull RATE-ENGINE.
- \* Recurring Service Over The Card.
- \* Auto creation card option for new callerID.

For further Information, please visit : [www.adoreinfotech.com](http://www.adoreinfotech.com)

## VOIP Billing Customer Module



[My Account](#) | [History](#) | [Invoices](#) | [DID](#) | [Speed Dial](#) | [Ratecard](#) | [Callback](#) | [Voucher](#) | [Caller ID](#) | [Misc Services](#) | [Support](#) | [Logout](#)

[USER MANUAL](#)

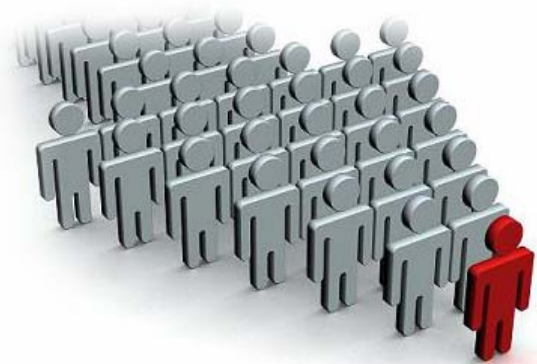

My CARD NUMBER :	8536
My BALANCE :	79.8 USD
<b>USER INFORMATION</b>	
LAST NAME	: 123456
FIRST NAME	: 123456
EMAIL	: support@adoreinfotech.com
PHONE	: 9211420840
FAX	: 011-22188745
ADDRESS	: Noida
ZIP CODE	: 110098
CITY	: Delhi
STATE	: Delhi
COUNTRY	: IND
<a href="#">EDIT USER INFORMATION</a>	



[BUY NOW](#)

### Benefits

- One Server for Adore all in one solution.
- User Friendly Billing Interface.
- Remote Installation.
- Online Training Program.
- Online Support.
- Quick Installation.



**Sales** : + 91 - 9958611014 (India)  
          + 91 - 120-6471891 (India)  
Toll Free : -1-800- 498-6429 (USA)  
Email : [sales@adoresoftphone.com](mailto:sales@adoresoftphone.com)

**Support**  
Tel : +91 - 120 - 6450129 (India)  
Email : [support@adoresoftphone.com](mailto:support@adoresoftphone.com)

